

Bar Stool Fabrication Notes

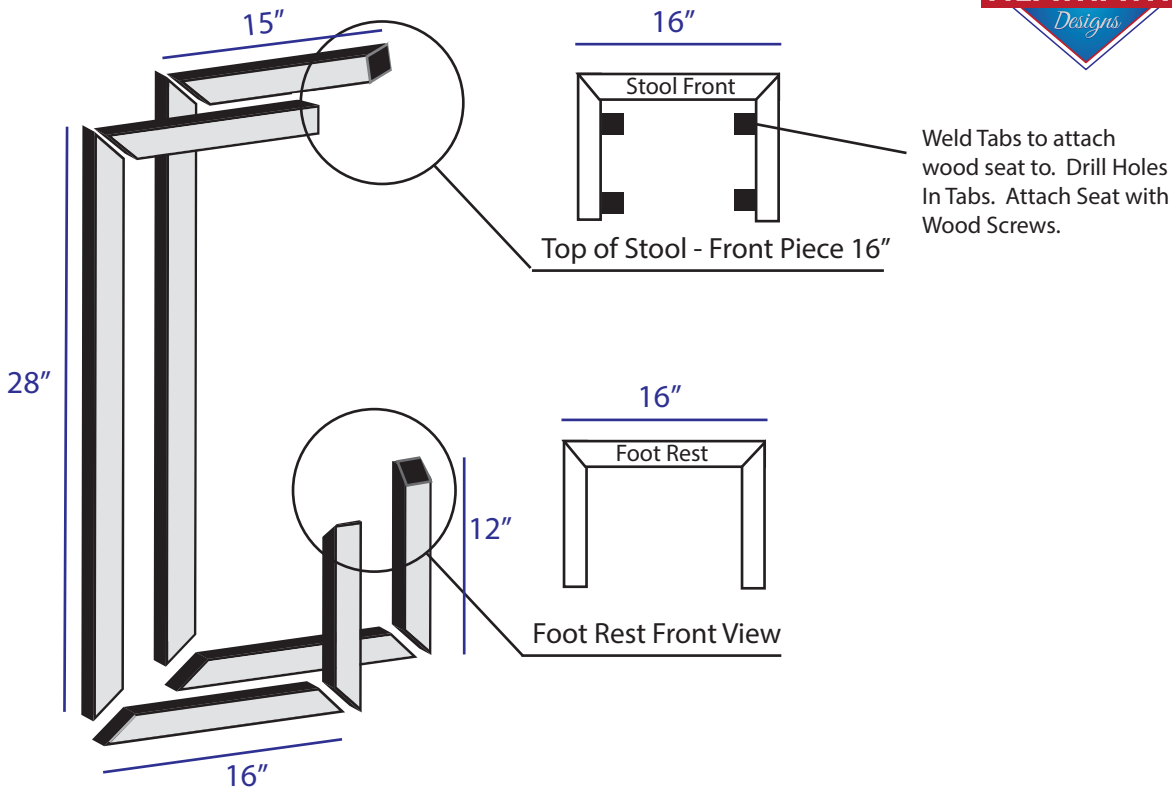

For this project we used 1/8" wall 1" x 2" Rectangular Steel Tubing

All measurements are from very edge to edge (Furthest point of 45 Deg. Angle).

These bar stools were made for a bar top @ 42" from floor

All Cuts at 45 degrees

Seat Measures 16 1/2" wide (side to side) x 15 1/2" long (front to back) and is about 1 7/8" thick.

Fully Weld All Joints.

For Fabricaion Video, Please visit: <https://youtu.be/N9I50lw6WIA>